

Product Profile

QDS Bolter

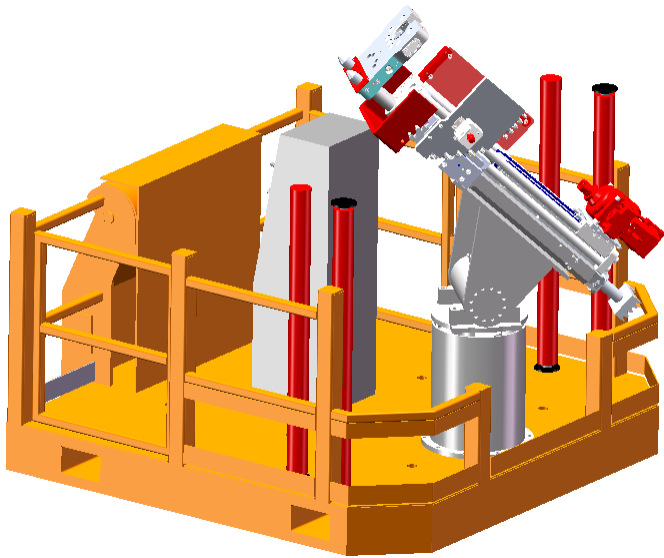

RUS QDS Bolter

The QDS Bolter be fitted to LHD with quick detach system , the bolter fit with two stab jacks and two mesh Jacks,registered engineer designed and construction certificate .

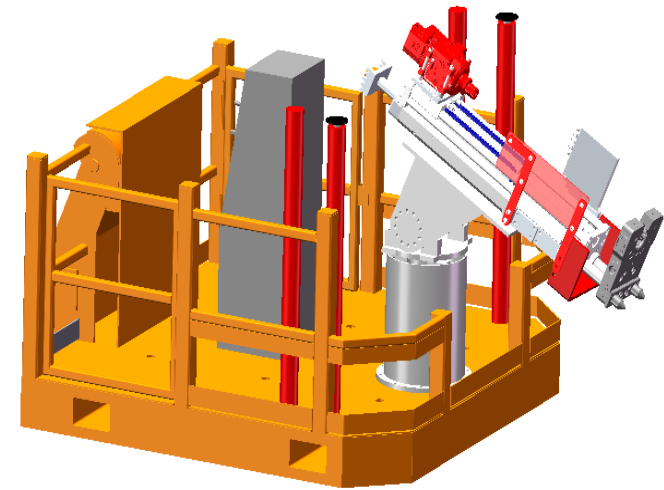

SPECIFICATIONS

Gross Weight	4.5 tonnes
Platform Size	3000mm x 2400mm
Mast Type	JK190 / 240
Height With Mast (JK190)	2100 mm
Height With Mast (JK240)	2250 mm
Mesh Jack Overall Height(extended)	3000 mm
Stab Jack Overall Height(extended)	3050 mm
Hydraulic System Pressure	2500 psi
Drill Motor	2-speed drill motor
Rig Vertical Rotation	105°
Rig Horizontal Rotation	180°
Safe Working Load (2 persons only)	500kg
Noise Output	85 dba

Your options:

- JK 190/240 Mast
- Bosch Rexroth Logic Manifolds for controlling hydraulic functions
- RUS Cable Feeder
- On board intensifier for tensioning

Contact

Head Office: 5 Montore Road, Minto, NSW 2566 Australia.
Postal Address: PO Box 322, Minto, NSW 2566
Phone: (02) 8796 9800
Fax: (02) 9824 8158
Email: Russales@rusmining.com.au